

**McFARLANE**  
MFG. CO.  
INC. *Sauk City, Wisconsin*

MANUFACTURERS OF QUALITY AGRICULTURAL EQUIPMENT SINCE 1936

OPERATOR'S MANUAL  
AND  
PARTS LISTING  
FOR THE

**CTM Series  
Mounted Harrow**

M&W 2200F  
Folding Disk Ripper

VERSION: 9-08 (MM-2315)

TO THE OWNER AND OPERATORS

Before assembling or operating this unit, READ THIS MANUAL THOROUGHLY. To obtain the best performance of the unit, familiarize yourself with each component and adjustment. Store this manual where it can be readily available for future reference. In the event that the harrow or any part of the unit should be sold, be sure that the new owner receives a copy of this manual for their reference.

1330 DALLAS STREET, P.O. BOX 100  
SAUK CITY, WISCONSIN 53583  
PHONE: (608) 643-3321  
TOLL FREE: (800) 627-8569 FAX: (608) 643-3976

## STEP - BY - STEP ASSEMBLY INSTRUCTIONS

### Attach the Main Mount Tubes

1. Attach the Main Mounting Tubes to the toolbar of the Disk Ripper using the bolts shown. Note that longer arms should be mounted between the 3<sup>rd</sup> and 4<sup>th</sup> shanks from the outside of the unit. Mount the shorter arms between the 2<sup>nd</sup> and 3<sup>rd</sup> shanks from the outside of the unit.

\*Note that the Main Cross Tube can be adjusted up and down on the Main Support Tube Plate. The height cannot be pre-determined because it will depend on the depth of Ripper settings.

2. Attach the Center Bar to the Main Support Tube Plates with the 3/4 x 6 1/2 bolts, lock washers, hex nuts and clamp plates provided. Before tightening bolts make sure that the tube is centered on the Mounting Plate. That is with equal amount of tube extending beyond the mounting plates on each end.
3. Attach the Wing Bars to the Center Bar using the hinge pins provided. Press a 3/8" x 2" spring roll pin into each end of the hinge pin and grease the hinge thoroughly through the zerk fittings on the hinge blocks. Check the movement of the wing to assure that it moves freely. Attach and plumb the hydraulic cylinders and make sure the wings fold freely.

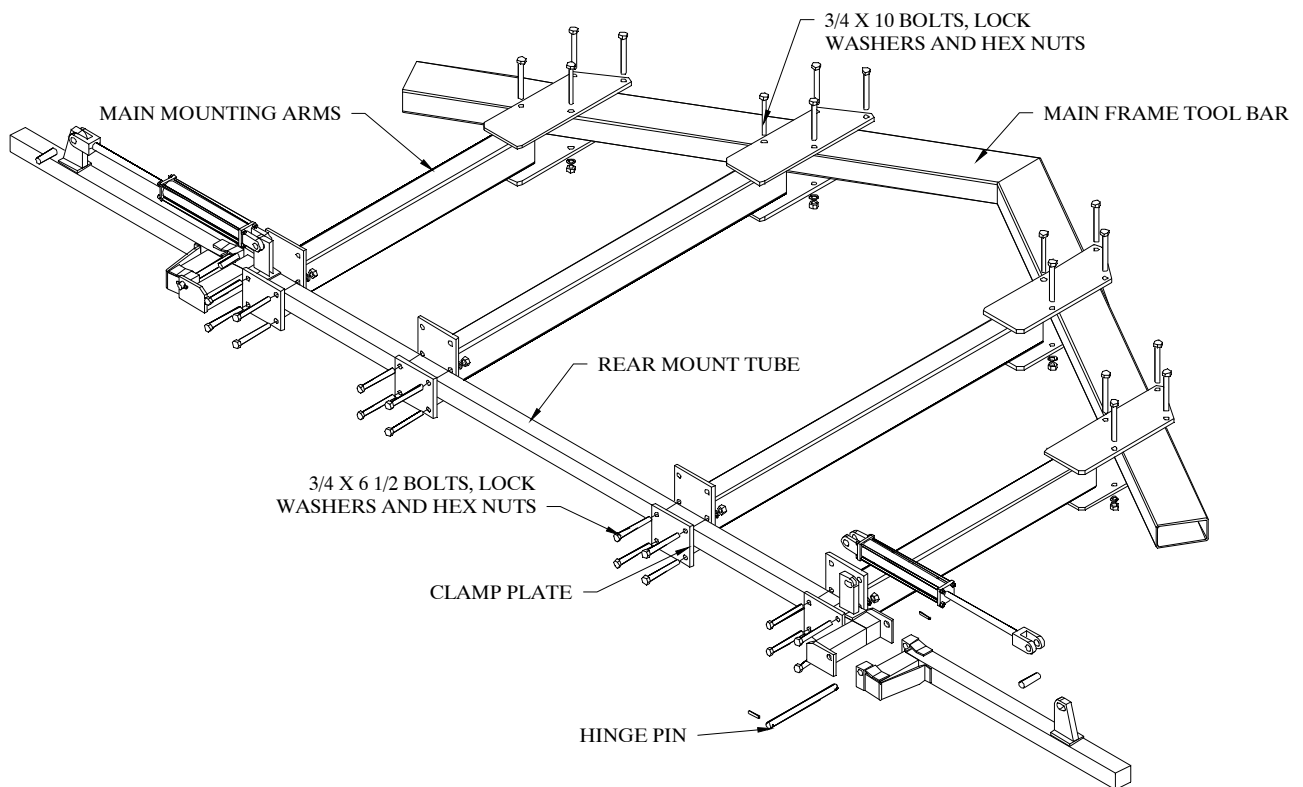

**CTM ATTACHMENT PARTS LIST  
FOR M&W FOLDING DISK RIPPER**

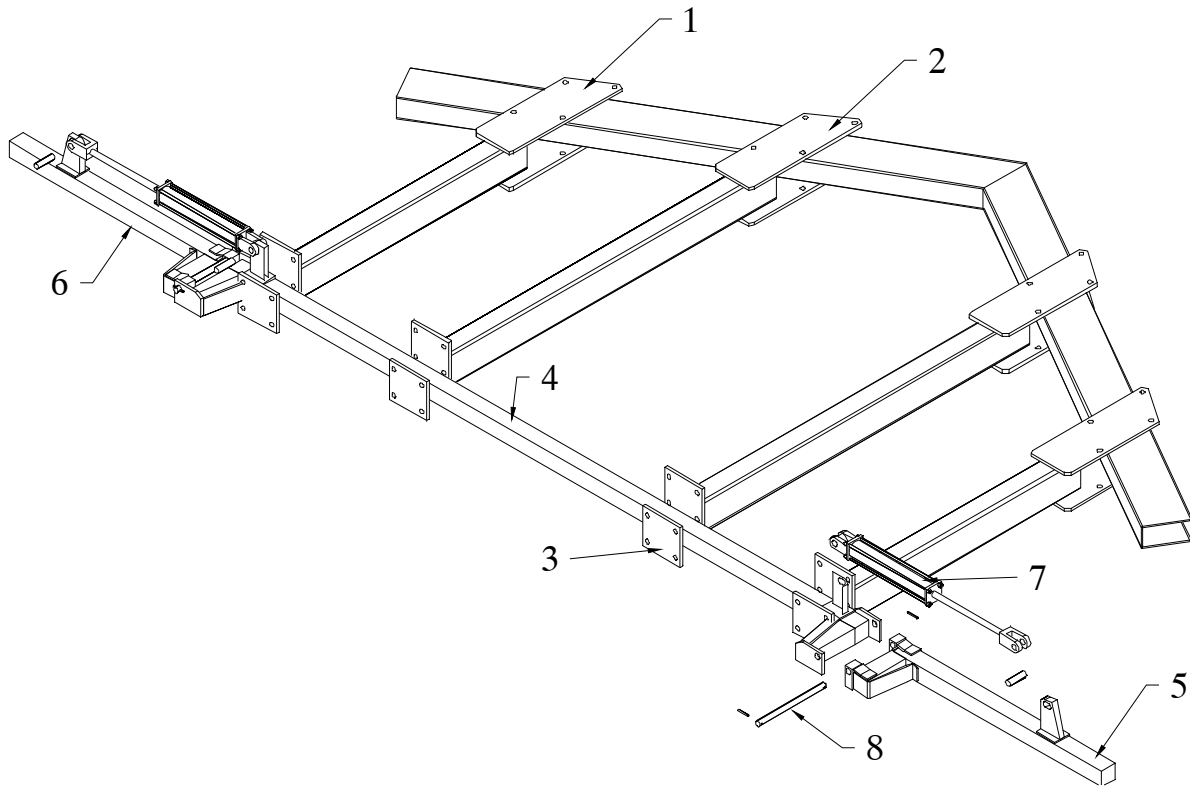

Always order by Part Number - *Not* by Key Number

| KEY | PART #   | DESCRIPTION                         |
|-----|----------|-------------------------------------|
| 1   | CTM-3579 | 61" MAIN MOUNT ARM, LEFT (2209-24)  |
|     | CTM-3580 | 61" MAIN MOUNT ARM, RIGHT (2209-24) |
| 2   | CTM-3585 | 81" MAIN MOUNT ARM, LEFT (2209-24)  |
|     | CTM-3586 | 81" MAIN MOUNT ARM, RIGHT (2209-24) |
| 3   | CTM-3502 | MAIN CROSS TUBE CLAMP PLATE         |
| 4   | CTM-6135 | MAIN CROSS TUBE CENTER BAR – 135"   |
| 5   | CTM-6267 | MAIN CROSS TUBE WING BAR, RT – 66"  |
| 6   | CTM-6266 | MAIN CROSS TUBE WING BAR, LT – 66"  |
| 7   | HYC-2014 | 2" X 14" HYDRAULIC CYLINDER         |
| 8   | CTM-6101 | WING HINGE PIN                      |

Bolts, washers, nuts, and cotter pins are not shown. Refer to the setup instructions for details.

**McFarlane Manufacturing reserves the right to change specifications of design at any time without obligation to modify previous products.**

# Layout Diagram for M&W Folding Disk Ripper

