

McFARLANE
MFG. CO.
INC. *Sauk City, Wisconsin*

MANUFACTURERS OF QUALITY AGRICULTURAL EQUIPMENT SINCE 1936

OPERATOR'S MANUAL
AND
PARTS LISTING
FOR THE

**CTM Series
Mounted Harrow**

For Sunflower 4411
7 Shank Disk Ripper

VERSION: 9-00AJF

TO THE OWNER AND OPERATORS

Before assembling or operating this unit, READ THIS MANUAL THOROUGHLY. To obtain the best performance of the unit, familiarize yourself with each component and adjustment. Store this manual where it can be readily available for future reference. In the event that the harrow or any part of the unit should be sold, be sure that the new owner receives a copy of this manual for their reference.

1330 DALLAS STREET, P.O. BOX 100
SAUK CITY, WISCONSIN 53583
PHONE: (608) 643-3321
TOLL FREE: (800) 627-8569 FAX: (608) 643-3976

STEP - BY - STEP ASSEMBLY INSTRUCTIONS

1. The main support tubes are to be attached to the right center 4 x 6 frame tube and the 2 x 6 support tube on the sides of the Disk Ripper. Please note that there is a left, center and right support tube. Be sure to identify each one before assembly
2. Attach the Center Support Tube using the 6 - 5/8 x 6 1/2 bolts provided. Be sure the support tubes are in the correct orientation, which can be see in figure 1 below. Attach the Side Support Tubes using the 6 - 5/8 x 4 1/2 bolts and 4 - 1/2 x 4 x 8 U-bolts provided. A layout diagram provided in appendix C shows the placement of the support tubes. Make sure that the center tube is the correct distance from the rear of the frame.
3. Attach the 4 x 4 - 200 Cross Tube to the Main Support Tube Plate with the 12 - 3/4 x 6 1/2 bolts, lock washers, hex nuts and clamp plates provided. Before tightening bolts make sure that the tube is centered on the Mounting Plate. That is with equal amount of tube extending beyond the mounting plates on each end.
4. Also note that this Main Cross Tube can be adjusted up and down on the Main Support Tube Plate. It may be necessary to adjust the height of this tube later to get the desired distance. Exact height of this cannot be pre-determined because it will depend on the depth of Ripper settings.

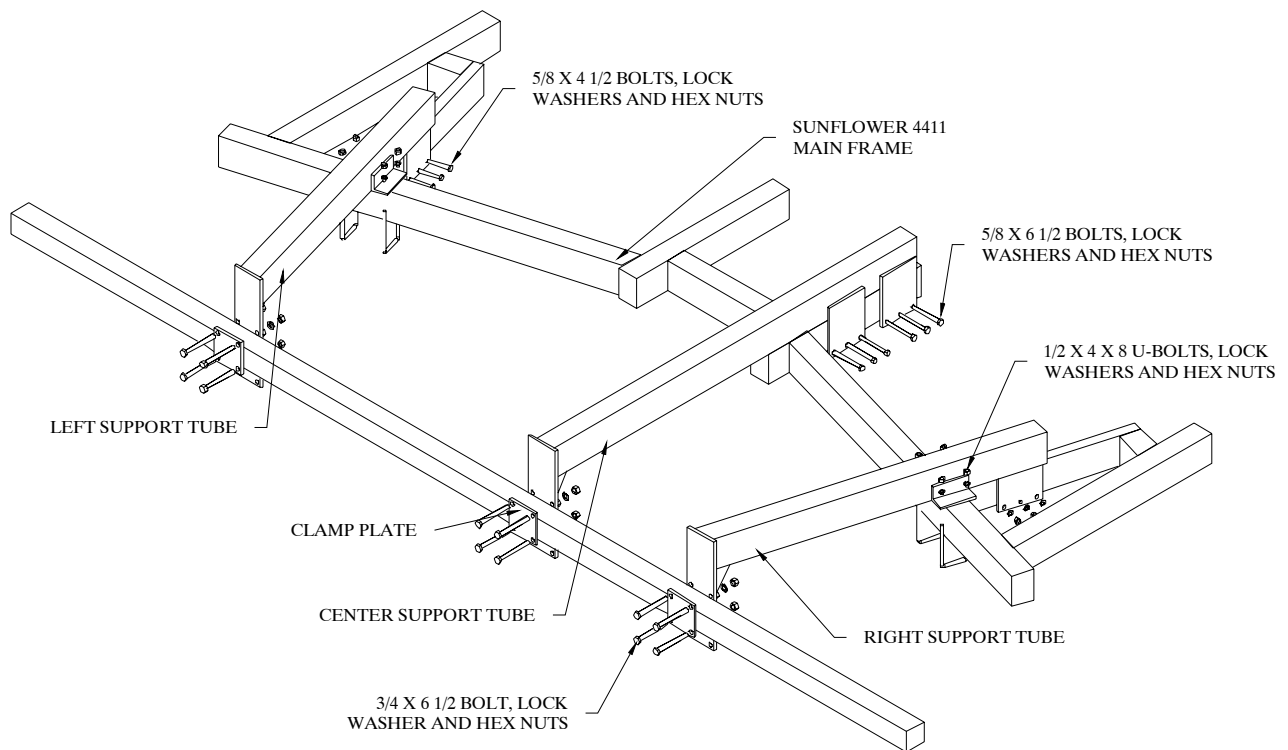
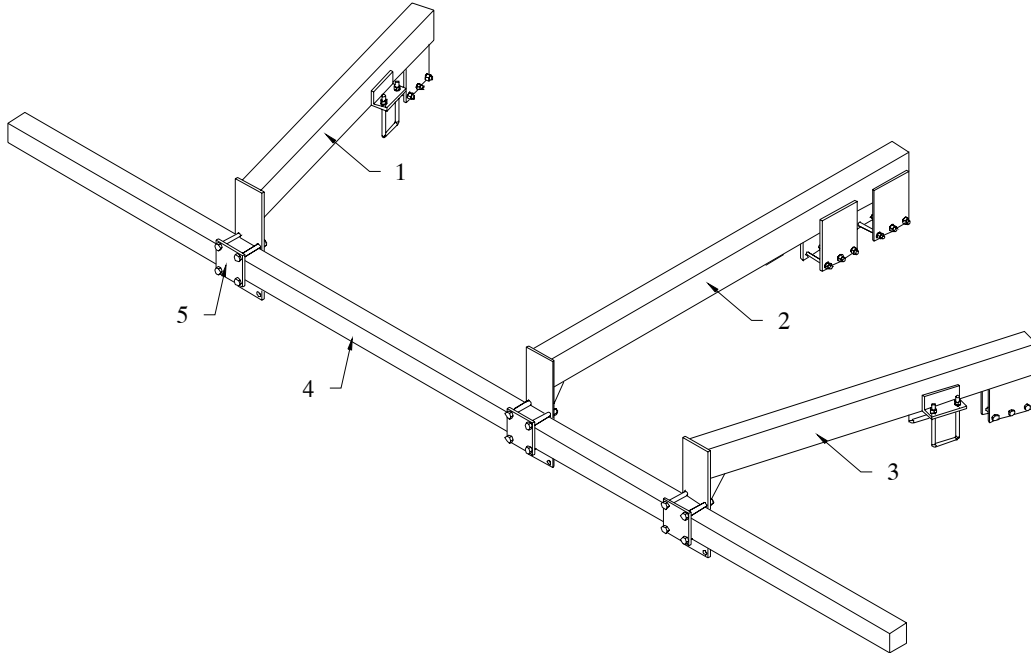

Figure 1

**CTM MOUNT PARTS LIST
FOR SUNFLOWER 4411 7 SHANK DISK RIPPER**



Always order by Part Number - *Not* by Key Number

KEY	PART #	DESCRIPTION
1	CTM-3650	MAIN SUPPORT TUBE – LEFT
2	CTM-3640	MAIN SUPPORT TUBE – CENTER
3	CTM-3651	MAIN SUPPORT TUBE - RIGHT
4	***	MAIN CROSS TUBE
5	CTM-3562	MAIN CROSS TUBE CLAMP PLATE

**** Please specify length when ordering these parts.

Bolts, washers, nuts, and cotter pins are not shown. Refer to the setup instructions for details.

McFarlane Manufacturing reserves the right to change specifications of design at any time without obligation to modify previous products.

**SUNFLOWER 4411 7 SHANK DISK RIPPER
4 BAR LAYOUT DIAGRAM**

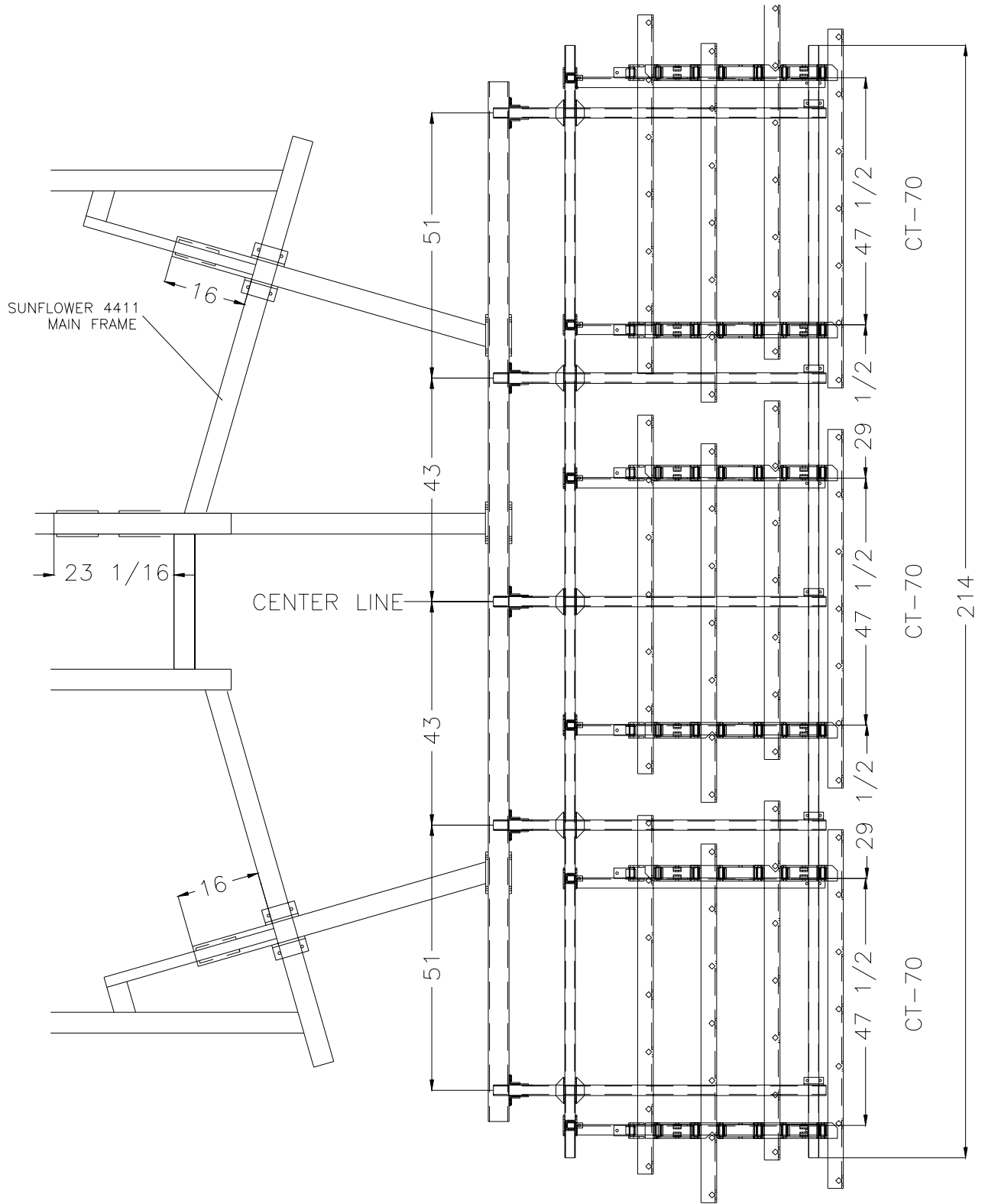

SUNFLOWER 4411 7 SHANK DISK RIPPER 5 BAR LAYOUT DIAGRAM

