



MANUFACTURERS OF QUALITY AGRICULTURAL EQUIPMENT SINCE 1936

OPERATOR'S MANUAL
AND
PARTS LISTING
FOR THE

**CTM Series
Mounted Harrow**

For JD 510 7 Shank Disk Ripper

VERSION: 9-03 (MM-2307)

TO THE OWNER AND OPERATORS

Before assembling or operating this unit, READ THIS MANUAL THOROUGHLY. To obtain the best performance of the unit, familiarize yourself with each component and adjustment. Store this manual where it can be readily available for future reference. In the event that the harrow or any part of the unit should be sold, be sure that the new owner receives a copy of this manual for their reference.

1330 DALLAS STREET, P.O. BOX 100
SAUK CITY, WISCONSIN 53583
PHONE: (608) 643-3321
TOLL FREE: (800) 627-8569 FAX: (608) 643-3976

STEP - BY - STEP ASSEMBLY INSTRUCTIONS

Attach the Main Mount Tubes

(Refer to Figure 1)

1. The main support tubes are to be attached to the side tubes of the Disk Ripper. Please note that there is a left and a right hand main support tube assembly.
2. Attach the Main Support Tubes to the side tubes of the Disk Ripper using the 6 - 5/8 x 6 bolts provided.
3. Make sure that the Main Support Tubes are mounted evenly on the side tubes. That means that they should be centered on the side tubes and that the distance from the rear of the side tubes of the Disk Ripper to the Mounting Plate on the rear of the Main Support Tubes is equal on both sides.
4. Attach the 4 x 4 - 240 Cross Tube to the Main Support Tube Plate with the 8 - 3/4 x 6 1/2 bolts, lock washers, hex nuts and clamp plates provided. Before tightening bolts make sure that the tube is centered on the Mounting Plate. That is with equal amount of tube extending beyond the mounting plates on each end.
5. Also note that this Main Cross Tube can be adjusted up and down on the Main Support Tube Plate. It may be necessary to adjust the height of this tube later to get the desired distance. Exact height of this cannot be pre-determined because it will depend on the depth of Ripper settings.

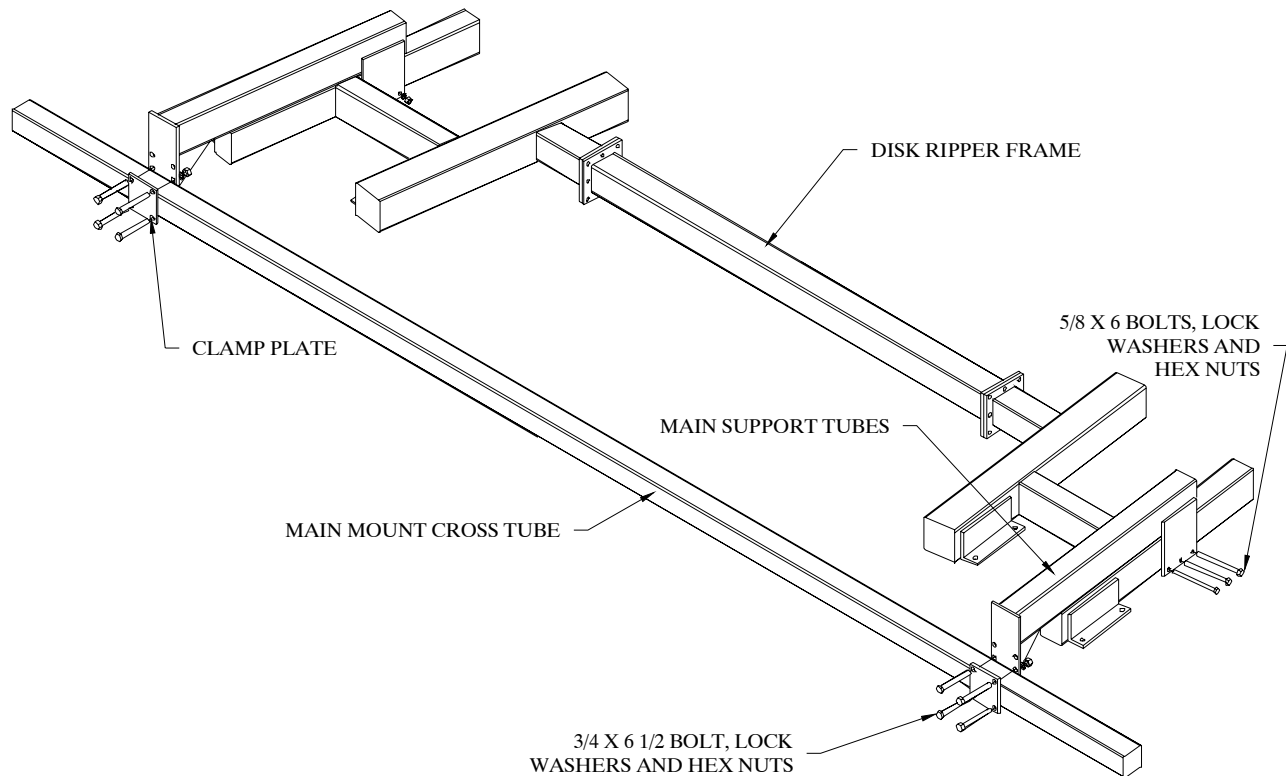

**CTM ATTACHMENT PARTS LIST
FOR JD 510 7 SHANK DISK RIPPER**

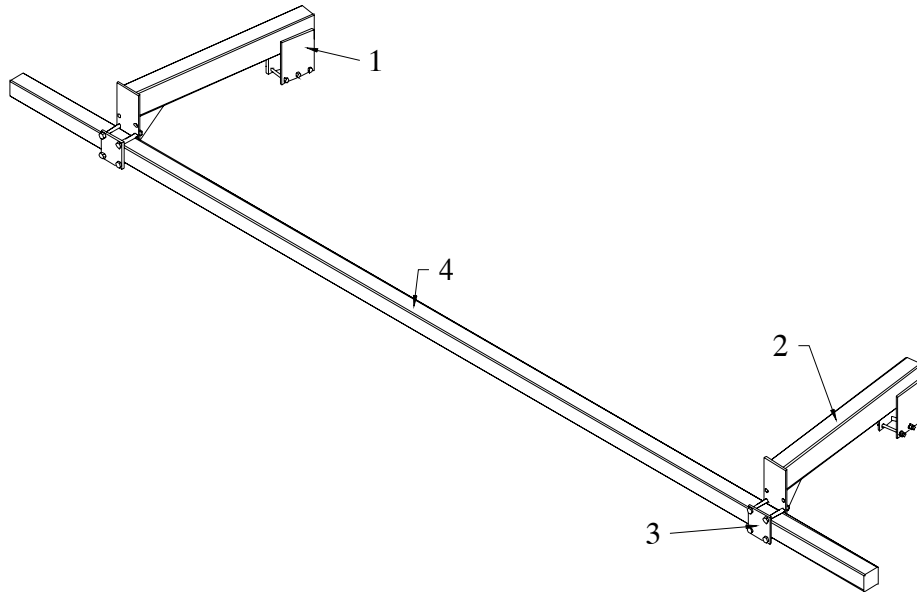

Always order by Part Number - *Not* by Key Number

KEY	PART #	DESCRIPTION
1	CTM-3591	MAIN SUPPORT ARM – LEFT
2	CTM-3592	MAIN SUPPORT ARM – RIGHT
3	CTM-3562	MAIN CROSS TUBE CLAMP PLATE
4	CTM-4240	MAIN CROSS TUBE

Bolts, washers, nuts, and cotter pins are not shown. Refer to the setup instructions for details.

McFarlane Manufacturing reserves the right to change specifications of design at any time without obligation to modify previous products.

Layout Diagram for JD 510 7 Shank

